



© by Tony van Roon (VA3AVR)



First a bit of history about the remarkable development of this 'relay' device. Joseph Henry (1797-1878), a brilliant US scientist who invented and used the electro-magnetic relay in his university laboratory. His low-power electro magnet could control a make-and-break switch in a high-power circuit. Henry believed the potential was in the relay's use as a control system in manufacture, but he was only really interested in the science of the electricity. The relay was a laboratory trick to entertain students. Samuel Morse later used Henry's relay device, after re-designing it using thinner wire, to carry morse-code signals over long kilometers of wire.

In 1846, Joseph Henry was professor of natural philosophy (physics) at the College of New Jersey (now known as Princeton University). He had published scientific articles on a wide variety of subjects, including electro magnetism, optics, acoustics, astrophysics, molecular forces, and terrestrial magnetism, but his reputation was built primarily on his work in basic and applied electro magnetism. Among his discoveries in electro magnetism were mutual induction, self-induction, the electro

magnetic relay--enabling him to devise the first electro magnetic telegraph that could be used over long distances--and the concept of the electric transformer. He also invented the first electric motor. Henry was often referred to as the scientific successor to Benjamin Franklin. Today, it is the general opinion that Joseph Henry was the inventor of the telegraph and not Samuel Morse, who did not have a technical background to begin with. Samuel Morse adapted the ideas and inventions of Henry (and Vail) into his own and patented it, making him the owner.

It is certain that Joseph Henry was important to the history of the telegraph in two ways. First, he was responsible for major discoveries in electro magnetism, most significantly the means of constructing electromagnets that were powerful enough to transform electrical energy into useful mechanical work at a distance. Much of Morse's telegraph did indeed rest upon Henry's discovery of the principles underlying the operation of such electromagnets.



Below are a couple other thoughts collected from the Smithsonian Institute (of which Henry was First Secretary), and Harvard University:

"... Secondly, Henry became an unwilling participant in the protracted litigation over the scope and validity of Samuel Morse's patents. ..."

"... Joseph Henry began his research into electro magnetism in 1827, while he was an instructor at the Albany Academy in New York. By 1830, he achieved two major breakthroughs His first crucial innovation, which he demonstrated in June 1828, was to combine Schweigger's multiplier with Sturgeon's electro magnet to obtain an extremely powerful magnet. While Sturgeon loosely wrapped a few feet of uninsulated wire around a horseshoe magnet, Henry tightly wound his horseshoe with several layers of insulated wire. In March 1829 he demonstrated an electro magnet with 400 turns, or about 35 feet, of insulated wire. This magnet, Henry remarked later, "possessed magnetic power superior to that of any before known."



"... Henry did set out to demonstrate the practicality of an electro magnetic telegraph immediately after his paper appeared. His prototype consisted of a small

battery and an "intensity" magnet connected through a mile of copper bell-wire strung throughout a lecture hall. In between the poles of this horseshoe electro magnetic he placed a permanent magnet. When the electro magnetic was energized, the permanent magnet was repelled from one pole and attracted to the other; upon reversing battery polarity, the permanent magnet returned to its original position. ... Henry caused the permanent magnet to tap a small office bell. He consistently demonstrated this arrangement to his classes at Albany during 1831 and 1832."

In short, this man, Joseph Henry, was a scientist and physicist by heart and a true teacher to his students. As a reward, they (not his students) stole his ideas and scientific experiments. For that reason I'm convinced that Morse was a fraud, preying on the ideas and inventions (like the telegraph) of others and putting his patent on it (obtained on October 3, 1837). I do credit Samuel Morse, however, for the morse-code, which is still used to this date and no person without a 5-wpm morse-code qualification exam can call him/herself a Advanced Radio Amateur! (see Fig. a).

Morse Code:

A .-	E .	I ..	M --	Q ----	U ...	Y ----
B	F	J. ---	N ..	R ...	V	Z ----
C	G ---	K ---	O ---	S ...	W ---	
D ---	H	L ...	P. ---	T -	X	

International Alphabet:

Alfa	Echo	India	Mike	Quebec	Uniform	Yankee
Bravo	Foxtrot	Juliet	November	Romeo	Victor	Zulu
Charley	Golf	Kilo	Oscar	Sierra	Wiskey	
Delta	Hotel	Lima	Papa	Tango	X ray	

Fig. a

Fig. 1

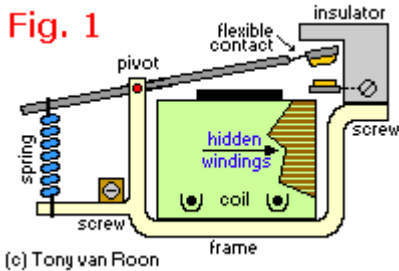

(c) Tony van Roon

Since this important day in 1836, when Joseph Henry transmitted a small electrical current down a wire to energize a remote coil and the completed circuit ringing a bell some 150 years ago, the relay has undergone steady evolution and today's relays are far removed from the crude and clumsy relays of Henry's days. In our millennium, solid-state has replaced the actual relay in many circuits, especially in AC applications. To sum it all up, the relay (and solenoids) have survived the tube, transistor, and integrated circuit (IC) eras.

Basically, a relay is an electrically operated switch, and actually the predecessor of the transistor. Solenoids are relays also but the very large types which carry huge amounts of current. Relays are the smaller types. Relays come in three types: electro mechanical, solid-state, and so-called hybrids which are a combination of the first two. There are also some specialized types that fall into neither category but I will deal with them later in this tutorial. Lets take electro-mechanical types first, they are available in three main models; armature, plunger, and reed. The **Armature Relays** are the oldest (see Fig. 1) but elegant. Plenty turns of very fine magnet-wire are wound around an iron core to form an electro-magnet. The movable metal armature has an electrical contact that is positioned over a fixed contact attached to the relay frame. A spring holds the armature up so that the movable and fixed contacts are normally separated (open). When the coil is energized, it attracts the pivoting armature and pulls it down, closing (make) the SPST contacts and completes the power circuit. Vice-versa, this relay can be made to open the contacts instead of closing them, or can do both either way. The armature relay is pretty old and no longer used in new applications, they do still exist however and are being used still at the time of writing this document.

Fig. 2

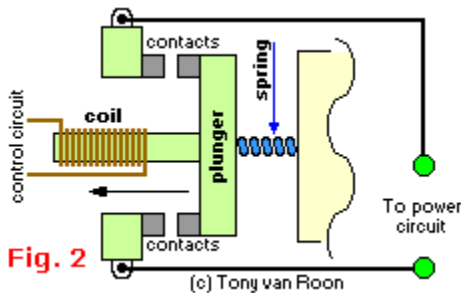

(c) Tony van Roon

The **Plunger-Relay** type have a plunger instead of a pivoting armature, as shown in Fig. 2 and uses a solenoid action to close the contacts. The electro magnetic core is hollow and a metal rod or plunger extends halfway through it when the relay is not energized. When energized, the coil draws the plunger in and a shorting-bar, attached to the end of the plunger, closes the contacts. When the coil is de-energized, the spring (which is mounted over a section of the plunger) retracts the plunger and positions the assembly in the idle position breaking the contacts. The coil plunger design allows much greater contact travel than the pivoting armature design, thus allowing wide contact separation. The increased space allows plunger systems to be used with higher voltages than armatures. The higher closing force of the solenoid permits the use of larger contacts and provides greater current handling capability. One application of a plunger-type relay is an electronic lock or door opener.

The **Plunger-Relay** type have a plunger instead of a pivoting armature, as shown in Fig. 2 and uses a solenoid action to close the contacts. The electro magnetic core is hollow and a metal rod or plunger extends halfway through it when the relay is not energized.

When energized, the coil draws the plunger in and a shorting-bar, attached to the end of the plunger, closes the contacts. When the coil is de-energized, the spring (which is mounted over a section of the plunger) retracts the plunger and positions the assembly in the idle position breaking the contacts.

The coil plunger design allows much greater contact travel than the pivoting armature design, thus allowing wide contact separation. The increased space allows plunger systems to be used with higher voltages than armatures. The higher closing force of the solenoid permits the use of larger contacts and provides greater current handling capability. One application of a plunger-type relay is an electronic lock or door opener.

Metal reed relay strips



Fig. 3

Since their inception, electro-magnetic relays have improved in sensitivity, switching complexity, current handling, response time, and reliability. It

allowed for miniaturization in radios, cassette recorders, Radio Control (R/C), NASA, cameras, and other home electronics applications. Being relatively small, **Reed Relays** fill the demand for all sorts of 'small' stuff. The use of flexible reeds and self-attraction distinguishes the reed relay, see **Fig. 3**, from other electro magnetic relays. Note that the drawing shows the reed-relay without the actuator coil. The contacts are mounted on thin metal strips (reeds) and hermetically sealed in a glass tube. This tube is surrounded by a magnetic coil which, when activated, magnetizes the reeds and causing them to attract each other which closes the contacts. When the coil is de-energized, the spring tension in the reeds causes them to separate again. This type of design has the advantages of high speed operation, long life, and very low price. One of the great advantages reed relays share with other electro magnetic relays is the relative ease with which they can be fitted with multiple contacts. As in the armature and plunger designs, the contact mechanisms can be stacked to provide multiple circuit-close or open designs, or even a combination of both, all activated by a single coil. In reed relays, multiple contact pairs, but in individual tubes, can be stacked and used with a single coil in a very small space. This is not a feature of solid-state relays.

Some Relay-driver Examples using regular components:

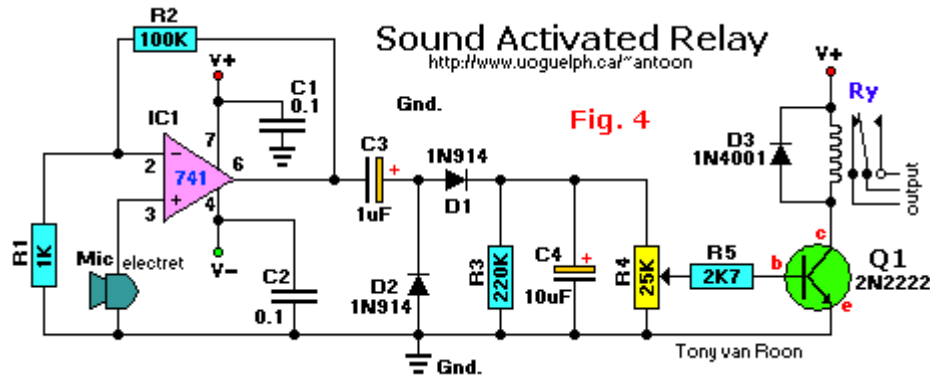

Fig. 4 Sound-Activated type. The relay remains dormant until the op-amp activates upon sound via the electret-microphone. The input stage is a regular off-the-shelf 741 operational amplifier and connected as a non-inverting follower audio amplifier. Gain is approximately 100 which you can raise by increasing the value of R2. The amplified signal is rectified and filtered via C3, D1/D2, and R4 to an acceptable DC level. Potentiometer R5 is used to set the audio level to a desired sensitivity value to activate the relay via transistor Q1. Diode D3 is mounted over the relay coil to absorb sparks. The op-amp configuration in this particular drawing needs a dual voltage power supply which can be made from two 9-volt batteries.

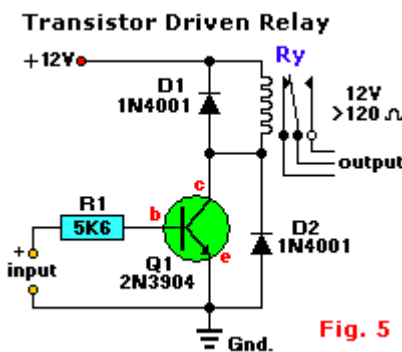
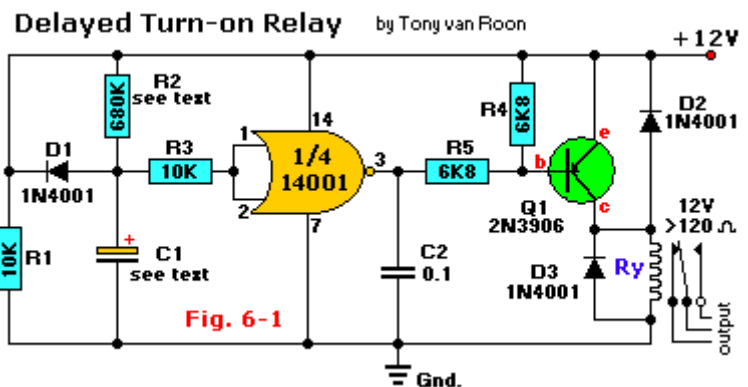
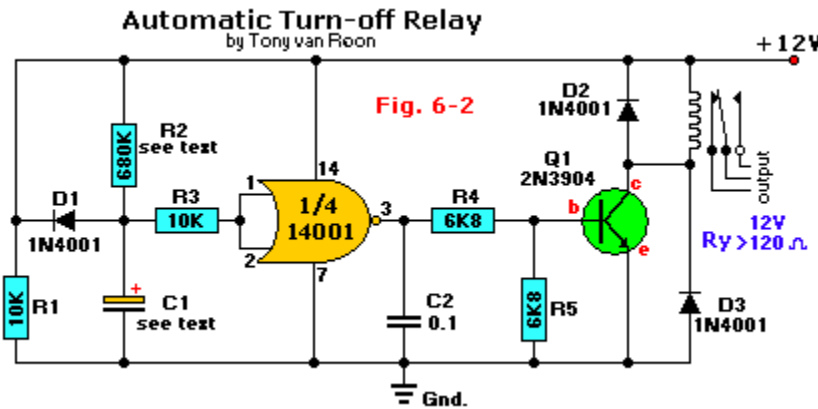

Fig. 5 **Fig. 6-1** is a **delayed turn-on**

relay driver and can produce time delays for up to several minutes with reasonable accuracy. The 14001 (or 4001) CMOS gate here is configured as a simple digital inverter. Its output is fed to the base of a regular 2N3906 (PNP) transistor, Q1, at the junction of resistor R5 and capacitor C2. The input to IC1 is taken from the junction of the time-controlled potential divider formed by R2 and C1. Before power is applied to the circuit, C1 is fully discharged.



Therefore, the inverter input is grounded, and its output equals the positive supply rail; Q1 and RY1 are both off under this circuit condition. When power is applied to the circuit, C1 charges through R2, and the exponentially rising voltage is applied to the input of the CMOS inverter gate. After a time delay determined by the RC time constant values of C1 and R2, this voltage rises to the threshold value of the CMOS inverter gate. The gate's output then falls toward zero volts and drives Q1 and relay RY1 'ON'. The relay then remains on until power is removed from the circuit. When that occurs, capacitor C1



discharges rapidly through diode D1 and R1, completing the sequence. The time delay can be controlled by different values for C1 and R2. The delay is approximately 0.5 seconds for every μF as value for C1. The delay can further be made variable by replacing R2 with a fixed and a variable resistor equal to that of the value of R2. Taken the value for R2 of 680K, it would be a combination of 180K for the fixed resistor in series with a 500K variable trim pot. The fixed resistor is necessary.

Fig. 6-2 is configured in an automatic turn-off mode. It shows how the circuit function of Fig. 6-1 can be reversed so that the relay turns on when power is applied but turns off again automatically after a preset delay. This response is obtained by modifying the relay-driving stage for an NPN transistor like the 2N3904. It is worth noting again that the circuits in **Fig. 6-1** and **Fig. 6-2** each provide a time delay of about 0.5 seconds for every micro-Farad in the value of capacitor C1. This permits delays of up to several minutes. If desired, the delay periods can be made variable by replacing resistor R2 with a fixed *and* variable resistor in series whose nominal values are approximately equal of the total value of R2 (680K).

1 to 100 Minute Timer Relay

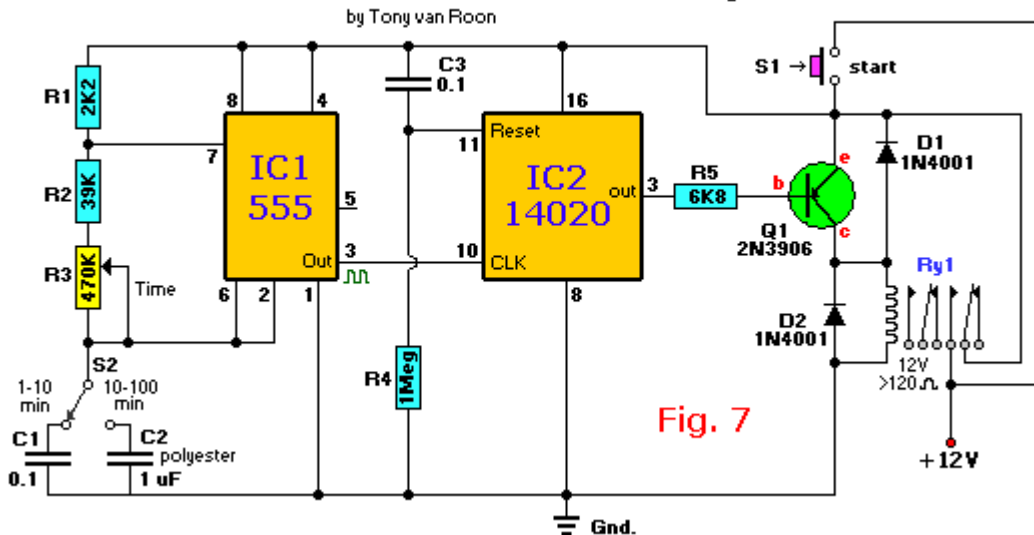
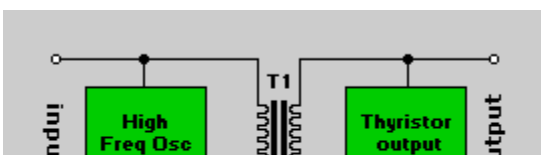

Fig. 7 This is an accurate **long-duration** time delay driver, switchable between 1 and 10 minutes or 10 to 100 minutes and whose function does not depend on electrolytic capacitors. Film dielectric caps have been selected. IC1 is configured as a free-running astable multivibrator which frequency is divided down by IC2, a 14020 (or 4020) CMOS 14-stage, ripple-carry binary divider. Consequently relay RY1 turns on as soon as switch S1 is closed, and it turns off again when the 8192nd astable pulse arrives. This method provides time periods ranging from 1 to 100 minutes, depending on the switch setting of S2.

Solid State Relays:



"Solid-State-Relay" (referred to as 'SSR' for short) means switching without any mechanical means. A solid-state **relay** is nothing more than a electronic switch, which can be a Triac, SCR, HexFet, or a High Speed MosFet, and an opto-isolator. Some are application dependent.

Control-to-load isolation is provided either by opto-isolators or transformers. Solid-state relays are available in AC and DC versions; **Fig. 8a/b/c/d/e** shows typical block diagrams. All approaches shown use an opto-isolator to separate the control and drive segments.

Virtually all solid-state relays are **Single-Pole Single-Throw, Normally Open (SPST-NO)** devices, where the outputs turn on in response to a control voltage. The majority take operating power from the control I/O, although some require separate DC logic power. The simplest DC input circuits use an LED optoisolator and series current-limiting resistor.

The resistor is usually sized for a 5-volt logic input, and results in a specified "ON" range of 3-6 volts DC. For wider operating ranges (typically 4-32 volts DC), the resistor is replaced by a constant-current diode. Then, AC input circuits rectify and filter the control input before applying it to the LED. Typical AC/DC LED currents can vary from 5 to 22mA.

AC and DC Outputs:

The optoisolator photocurrent is amplified and used to drive whatever output device the relay is connected to, whether a transistor for DC outputs, a thyristor for AC, or a power MOSFET for either. The power for the drive circuitry is taken either from the output load or is supplied separately. In some MOSFET designs, the photocurrent is sufficient to drive the output device.

Output	AC or DC	Package Style	Max Load Currents	Max Load Voltages	Volt Drop (on) at Rated Load	Leakage Current (off) At 25°C
Bipolar Transistor	DC	Dual Inline (DIP)	500mA 50mA	60Vdc 250Vdc	1 - 1.5V	20µA
		Input/ Output Module	3.5A 1A	60Vdc 200Vdc	1.2 - 1.75V	10µA - 1mA
		Power	2 to 20A	50Vdc	1.5 - 2V	5 - 15mA
		Power (High Voltage)	to 5A	250Vdc	2V	10µA
Thyristor (Triac or SCR)	AC	Dual Inline (DIP)	0.3 to 1A RMS (to 3A RMS on heat sink)	140 or 280V RMS	1.5V max	10µA - 1mA
		Input/ Output Module	3.5A RMS	140 or 280V RMS	1.5V max	2 - 5mA
		Power	10 - 40A RMS	140 to 280V RMS	1.5V max	2 - 15mA
Power MOSFET	AC DC	Dual Inline (DIP)	100 - 500mA (Some to 1A)	60 - 300V	Resistance 0.25 - 50 ohms	Resistance typically 100Meg

Table 1 summarizes typical specifications.

Normally, DC output devices like those in Figs. 8-Fc and Fd use an NPN transistor and may include a Zener diode across the output for transient suppression. The transistor will drop some voltage in the "ON" state, and the drive circuit will need some current to operate. Typical output drop is 1-2 volts at the full rated load current, while the "OFF"-state leakage may range from approximately 10µA-1mA.

Most AC output devices include zero-voltage-switching circuitry. Logic detects when the AC load voltage crosses zero (changes polarity) and delays the triac turn-on pulse until then. The triac turns on at the next zero crossing after the input goes high. Once triggered, it remains on until its current goes to zero. Zero-voltage and zero-current switching minimize transients and **ElectroMagneticInterference (EMI)**. The RC snubber in Fig. 8-Ff suppresses rapid voltage changes that can inadvertently turn on the thyristor.

In some applications, having the output turn on instantly is desirable. Relays referred to as "random turn-on" are designed without zero-voltage switching. Turn-off still occurs at zero-current, due to the inherent latching effect of thyristors. As with DC output relays, the thyristor drops voltage while conducting, while the drive circuitry requires power to operate. In addition, the snubber passes AC leakage in the "OFF" state. Typical "ON"-state

voltage 1.6 volts, while "OFF"-state leakage is 2-20mA for 60Hz power.

With recent advantages in power MOSFET's, solid-state relays can be designed with lower "ON"-state voltage drops, and greatly reduce "OFF"-stage leakage. These MOSFET's (and HexFets) offer bidirectional current flow, near-zero gate-drive current, no inherent source-to-drain offset voltage, and low "ON"-state (rDS) resistance and "OFF"-state leakage.

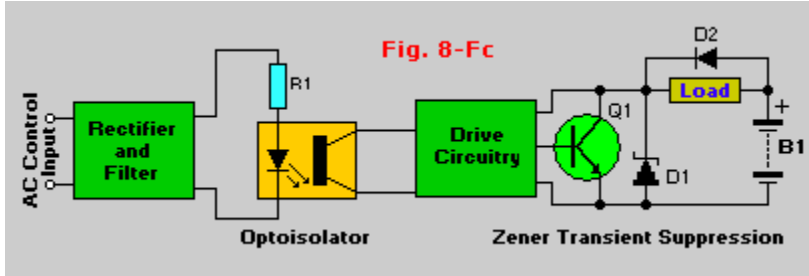

Most FET-output relays are housed in Dual-Inline-Packages (DIP's). Their main use is as a replacement for reed relays, where low offset and low leakage are important, and for control of low-power AC/DC loads. High power AC loads are best controlled by thyristors, which are easily controlled for zero-voltage turn-on; they also offer inherent zero-current turn-off, and produce lower

output-voltage drop at high currents.

However, FET design involves tradeoffs in voltage, current and resistance specs. In particular, high-voltage FET's have higher "ON" resistances, making them unsuitable for switching high-current line-voltage loads. Typical DIP relays have 70-500mA current ratings, "OFF"-state leakage resistances of 100 MegaOhms or more, and "ON" resistances from about one ohm for a 60-100 volt rating, to 25-50 ohms for a 300-400 volt rating. Switching times range from 10-100µSec.

I/O Isolation:

The majority of solid-state relays use opto-isolators. All off at least 1.5 kilo-volt RMS I/O breakdown, and 2.5 or 4 kilo-volt ratings are common. Most of them have been rated, listed, or approved by safety agencies like UL, CSA, and VDE. Transformer coupling is also used to isolate solid-state relays.

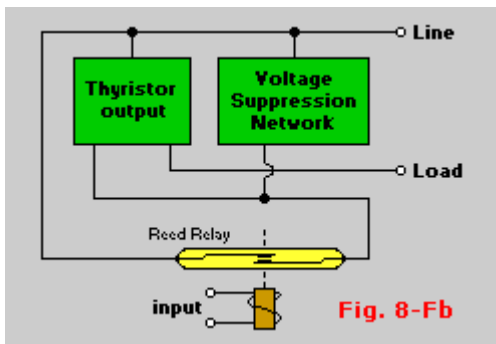

Fig. 8-Fc shows a transformer-coupled AC-output relay; DC and AC/DC FET relays are also available with transformer coupling. The control input powers an oscillator, the output which is coupled through a small pulse transformer to trigger the output thyristor. Circuitry of the type shown produces random turn-on operation; transformer-coupled relays generally don't include zero-voltage switching circuitry.

Transformer coupling allows faster switching. The oscillator frequency is typically 1-3MHz, resulting in switching times as low as 1µSec. Opto-isolators exhibit slower response, with times for DC versions typically 10 to 100µSec. They can be designed for slightly higher temperatures, being

free of LED limitations. However, achieving breakdown voltages above 1.5 kilovolts is easier using optical techniques.

Hybrid Relays:

Hybrid relays marry reed relays with a solid-state power output. **Fig. 8-Fb** shows a thyristor version; DC outputs are also offered. The hermetically sealed reed contacts switch only low power, and last 10 million operations or even longer. The turn-on time is that of the reed relay, about 1 mSec. Other hybrid relays are the reverse, using a solid-state input amplifier driving a reed-relay output, the obvious advantage being high input sensitivity. The term "hybrid" sometimes describes construction technique, rather than method of operation. In some catalogs you'll find hybrid solid-state relays with no mechanical components at all.

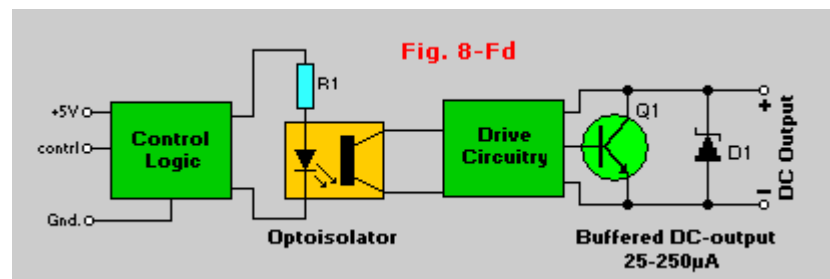

Self-Powered and Buffered Relays:

So far, all the relays that have been discussed until now have been "self-powered," in that they take operating power from the applied signals. All models, whether optoisolated, transformer coupled, or hybrid, require approximately 5-50mA at their inputs. Some, notably thyristor-output relays with zero-voltage switching, also take operating power from output loads, although none require separate power connections.

Buffered relays offer improved input sensitivity at the expense of needing separate DC power, and are usually used in systems that already include DC power supplies (not as stand-alone devices). **Fig. 8-Fd** shows a buffered DC-output relay. The input circuitry and the LED are powered from a separate logic supply, allowing the logic input current to be typically 25-250 μ A.

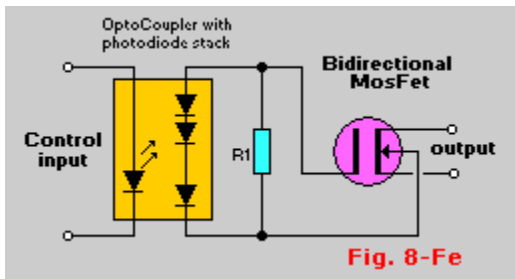

Due to near-zero gate current, power MOSFet's can be driven directly from a series stack of photodiode junctions. The "photo voltaic-generator" stack from International Rectifier shown in **Fig. 8-Fe** is constructed using IC fabrication techniques, and exposes a series of photo diodes to LED illumination. No operating power is required from the load.

Package Styles:

Solid-State relays are generally grouped into DIP's, power relays, and I/O modules. DIP relays are available with transistor (DC), thyristor (AC), or MOSFET (AC/DC) outputs, and with optoisolator or transformer coupling. Most power relays are used to switch AC power, and use thyristor switching with optoisolator coupling. Transistor (DC) outputs and transformer coupling are also available. I/O modules are always opto-coupled, and don't offer MOSFET outputs;

Safety Issues:



Building an SSR requires putting 115/220 volts on a printed circuit board. From an electrical point of view, that can be perfectly safe. However, it is good practice to cover all printed circuit tracks on the 115/220VAC side with a silicon sealer, varnish, lacquer, or even nail polish. Couple layers will do fine. Also, try to use only isolated Triacs (where the case is electrically isolated from the Triac), and ground the heat sink to the AC safety wire (earth ground, or green wire).

Choosing a Triac:

There are three basic requirements when choosing the output Triac. First is to make sure that it will handle the voltage required. The minimum for a 115-volt AC line requires a 200-volt Triac. A 220-volt line requires a 400-volt Triac. Remember that those are the minimum so, for a few cents more, it pays to use the next highest voltage rating.

The next requirement is current. A 6-amp Triac will handle 6 amps only if it is properly heat sinked. As a word of warning, motors draw a lot more current on start-up than they do during normal operation, sometimes as much as ten time more. Keep that in mind when you design your own.

The third requirement is the gate current. The Motorola MOC3010 optoisolator will provide about 100 milliamps of drive current for the output Triac. That should be adequate for any Triac you can find in a TO-220 package. Just in case it is not sufficient for your design, you can use a transistor as a current-sink.

Although not really a strict requirement, an isolated Triac is good practice and a good safety precaution. Isolated Triacs (usually listed in catalogs as iso-tab) provide electrical isolation from the electrical connections to the case. Early Triacs were not normally isolated. That meant that you had to use mica washers and thermal grease. Thermal grease is still a good idea, but the mica washer isn't required for isolated Triacs. If you don't know whether or not your Triac is isolated, simply measure the resistance from each lead to the case. An isolated Triac will measure open on all three leads.

Warning: The Radio Shack 400-volt, 6-amp Triac (part number 276-1000) will work well but is NOT isolated. You *must* use a TO-220 mica washer and thermal grease if you plan to use that device.

Zero-Voltage Switching:

I can hear you mumbling already... "what the heck is zero-voltage switching..."? In normal operation the trigger side of the relay is totally asynchronous to the AC side. That means that a trigger could occur during any part of the sine wave. If the trigger occurs near a peak (90 or 270 degrees), a large current will flow into the load almost instantly. That creates a lot of RFI (Radio Frequency Interference) and also is very hard on the filament of ordinary light bulbs. In order to prevent that, zero-crossing SSR's accept the trigger at any time but delay turning on the AC load until the next time the AC voltage passes through zero volts. Now you know. I personally don't use any other type.

Construction of a SSR:

Below is good working Solid State Relay using an opto-isolator and a Triac. Use of the shown printed circuit board is highly recommended but not required. **Remember to isolate the AC tracks when you're all done!**

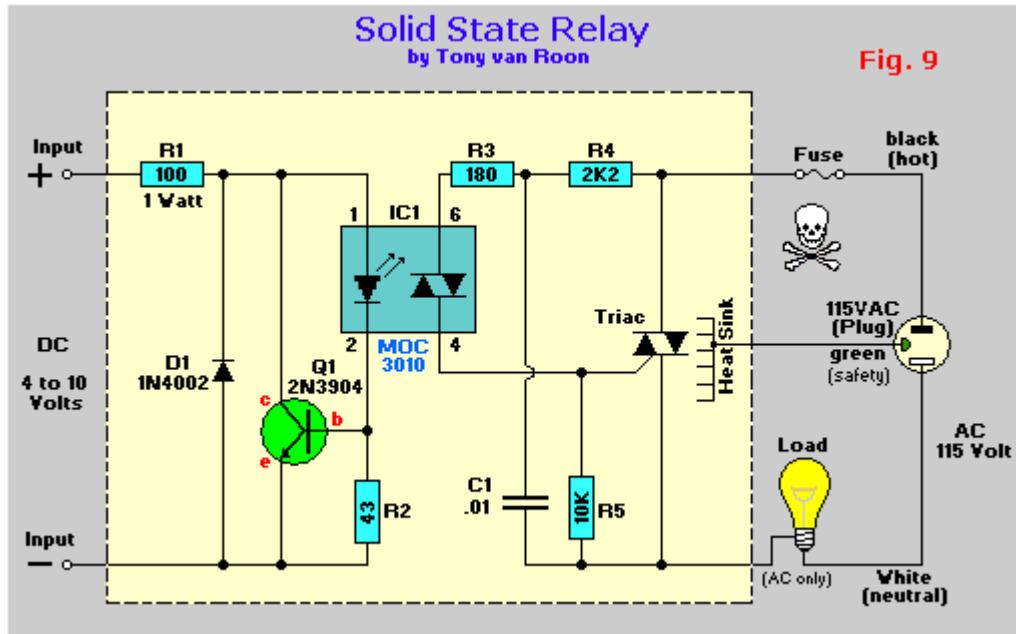

Fig. 9

For a simple SSR, an optoisolator such as the Motorola MOC3010 or the NTE3047 will be sufficient. For a zero-crossing SSR, a MOC3031 or NTE3049 will do. Many companies make optoisolators. Make sure yours has a "Triac output" and that the pinouts are compatible with your design. Table 2 shows some typical Triac output optoisolator specifications. The models shown are already a decade old but still widely used and available.

Again, although the SSR can certainly be built without using the PCB, using one makes assembly using the layout in Fig. 9 a snap.

The only precaution, other than the one about working with 115/220/220 AC volts, is to heatsink the Triac. If you leave the leads on the Triac long, it should be a simple matter to find some heat sink to attach to the Triac. Just remember to connect the heat sink to earth-ground. Even if you're using an isolated tab Triac, the earth ground is still necessary. Otherwise you should buy your solid-state relays from a reliable company--don't build them yourself.

Remember that SSR's can only switch an AC line. Trying to switch a DC line will result in a relay that closes but never opens... Have fun!

Couple More Circuits To Play With:

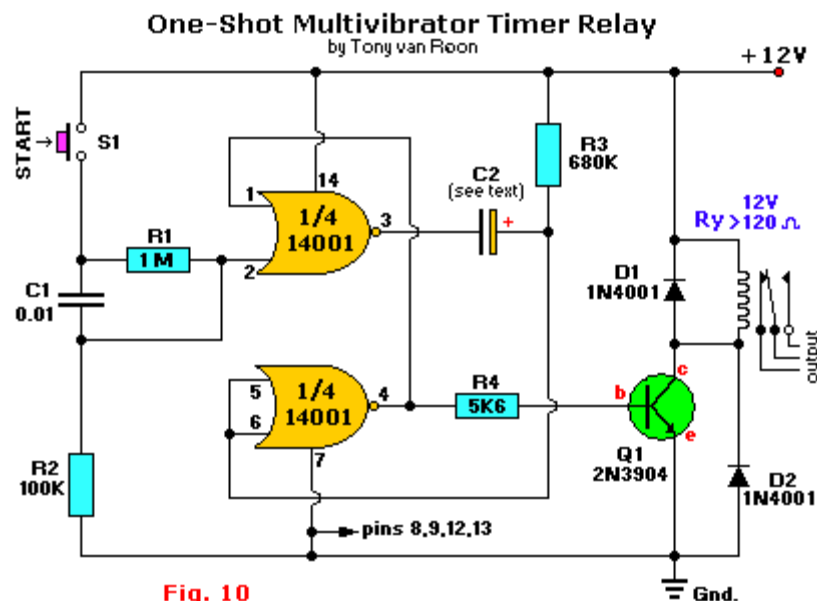

Fig. 10

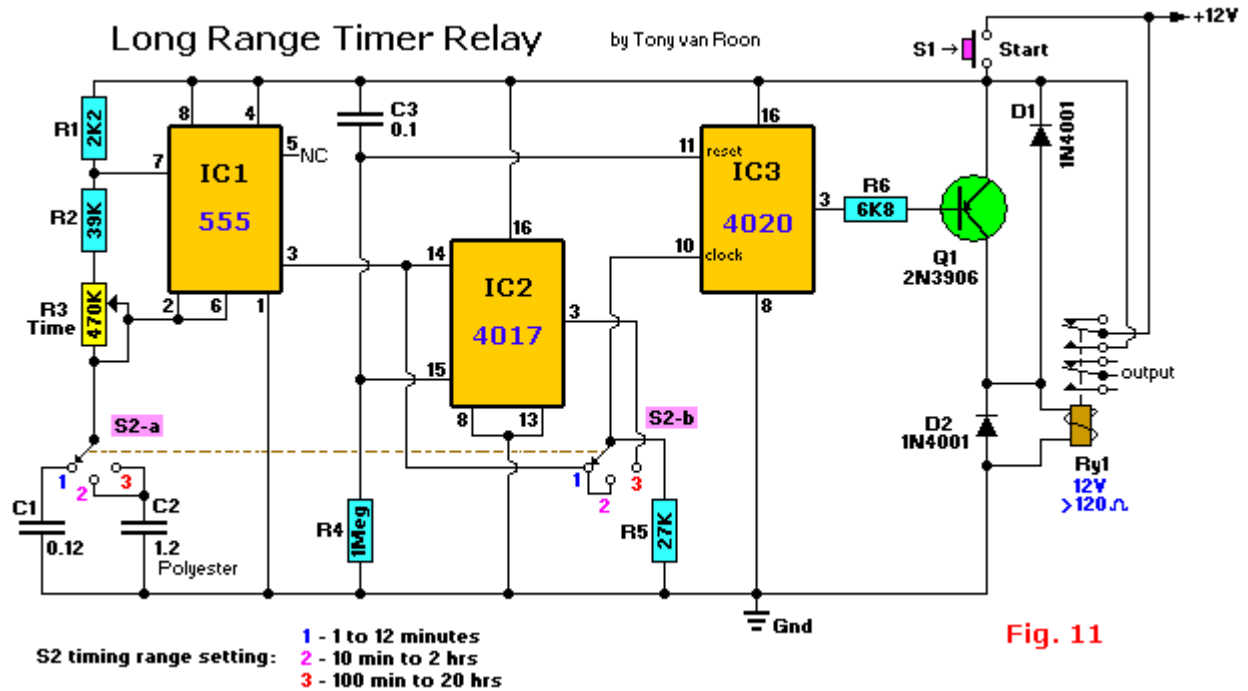

Fig. 10: This circuit shows a pair of CMOS NOR gates which form a push-button-activated one-shot multivibrator relay-switching circuit that provides delays up to several minutes with reasonable accuracy. The relay turns on as soon as the START switch S1 is closed. However, it turns off again after a preset delay of about 0.5 seconds per microFarad (μF) of the value of capacitor C2. The two CMOS gates are configured as a manually-triggered monostable multivibrator whose output is fed to the relay through R4 and transistor Q1.

Fig. 11: This one shows a 'long-range timer relay' switching circuit which spans 1 minute to 20 hours in three ranges using a three-step, two-deck mechanical rotary switch. IC1, the 555 timer/oscillator does the time IC2 (4017) is a CMOS decade counter IC, a five-stage Johnson counter with 10 decoded outputs. Inputs include a CLOCK, a RESET, and a CLOCK INHIBIT signal. This IC, together with IC3 and the 3-step rotary switch, can provide a maximum division ratio of 81,920 making it possible to time for periods up to 20 hours or so. Circuits like this are used in battery chargers and area security lighting systems with time-controlled turn-off. IC3 (4020) is a CMOS 14-stage, ripple-carry binary divider. Normally a 'high' would occur as soon as switch S1 is closed and a 'low' when the 8192nd astable pulse arrives. All counter stages of IC3, the 4020, are master-slave flip-flops. The state of a counter advances one count on the negative going transition of each input pulse, and a high level on the RESET line resets the counter to its all zeros state. All inputs and outputs are buffered.

Copyright and Credits:

"Relay Output Circuits", by Ray Marston, *Electronics Now Magazine*, July 1994.

"All About Relays", by Harry L. Trietley, *Radio Electronics Magazine*, December 1989.

"Winning the Relay Race", by Alvin G. Sydnor, *Popular Electronics Magazine*, August 1989

Re-posting or taking graphics in any way or form of this project is expressly prohibited by international copyright © laws. By written permission only.

Copyright © 2003 - Tony van Roon (VA3AVR)

Last updated: May 19, 2004